

BIMOTA KB4

Motorcycle Assembly & Preparation Manual



Foreword

In order to ship Bimota vehicles as efficiently as possible, they are partially disassembled before crating. Since some of the most commonly removed parts have a direct bearing on a vehicle's reliability and safety, conscientious pre-sale assembly and preparation be-comes extremely important. Good setup procedures can prevent needless warranty claims and give customers a greater sense of confidence in Bimota and their Bimota Dealers. This Assembly and Preparation Manual explains step by step procedures of the following items for all Bimota KB4.

1. Uncrating
2. Assembly
3. Preparation

The selling dealer assumes sole responsibility for any unauthorized modifications prior to sale. Refer to your Service Binder for any Service Bulletins specifying Factory Directed Modifications (Special Claims) which must be performed before the vehicle is ready for sale.

Whenever you see the following symbols heed their instructions! Always follow safe operating and maintenance practices.

DANGER

DANGER indicates a hazardous situation which, if not avoided, will result in death or serious injury.

WARNING

WARNING indicates a hazardous situation which, if not avoided, could result in death or serious injury.

NOTICE

NOTICE is used to address practices not related to personal injury.

NOTE

○ *NOTE* indicates information that may help or guide you in the operation or service of the vehicle.

Bimota spa accepts no liability for any inaccuracies or omissions in this publication, although every possible measure has been taken to make it as complete and accurate as possible. All procedures and specifications subject to change without notice.

Table of Contents

<u>Uncrating</u>	4
Opening Crate.....	4
Parts Check	8
<u>Assembly</u>	9
Windshield.....	9
Mirror assy.....	10
<u>Preparation</u>	11
Battery Service.....	11
Engine Oil(4-stroke)	13
Coolant	14
Clutch.....	16
Drive Chain.....	17
Brakes	18
Suspension system	20
Wheels	25
Headlight	26
Remove anticorrosive treatments	27

Uncrating

Opening Crate

⚠ WARNING

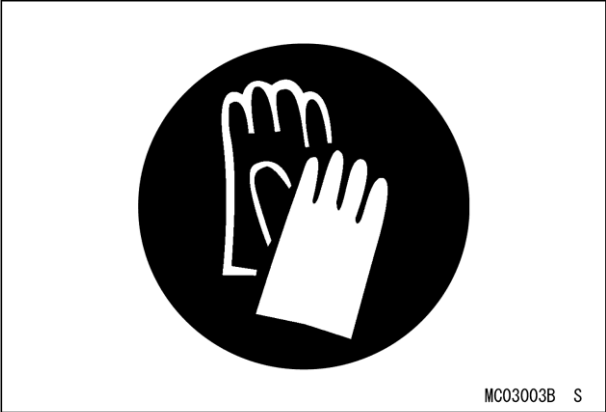

Crates have sharp edges and may have nails or screws that can cause cuts and injury. Always wear protective gloves, boots and eye protection when uncrating to prevent injury.



Figure 1 Screwdriver

⚠ WARNING

The steel crate panel plates and fasteners have sharp edges. Always wear protective gloves, boots and eye protection when uncrating to prevent injury.



Figure 2 Torx wrench adapter









Content of the box



Pre-assembly windshield

Continental Continental Automotive Components Malaysia
2401, 1st Fl, Tropic Inn, Jalan 28, P.16
Industrial Estate, 15000 Penang Malaysia

SIMPLIFIED EU DECLARATION OF CONFORMITY

METER

Continental Connected Cluster 1.0

Int English	Hereby, Continental Automotive Components Malaysia declares that the radio equipment type "Continental Connected Cluster 1.0" is in compliance with Directive 2014/53/EU.
Int French	Le fabricant Continental Automotive Components Malaysia déclare que le matériel radioélectrique "Continental Connected Cluster 1.0" est conforme à la directive 2014/53/UE.
Int German	Träger Continental Automotive Components Malaysia erklärt, dass das Funkgerät "Continental Connected Cluster 1.0" in Übereinstimmung mit der Richtlinie 2014/53/EU steht.
Int Danish	Continental Connected Cluster 1.0 er i overensstemmelse med direktiv 2014/53/EU.
Int Dutch	Hierbij verklaart A. Continental Automotive Components Malaysia, dat het type radioapparaat "Continental Connected Cluster 1.0" overeenstemt met Richtlijn 2014/53/EU.
Int Italian	Kelompokan Perangkat Radio Continental Automotive Components Malaysia, di sini menyatakan kepatuhan tipe "Continental Connected Cluster 1.0" sesuai dengan 2014/53/UE.
Int Spanish	El fabricante Continental Automotive Components Malaysia declara que el dispositivo radioeléctrico "Continental Connected Cluster 1.0" es conforme a la Directiva 2014/53/UE.
Int Polish	Tu niniejszym, Continental Automotive Components Malaysia, deklaruje że wyposażenie radiotelefoniczne A. typu "Continental Connected Cluster 1.0" jest zgodne z dyrektywą 2014/53/UE.
Int Czech	Prohláším, že typ "Continental Connected Cluster 1.0" je v souladu s direktivou 2014/53/EU.
Int Slovak	Prohlásim, že typ "Continental Connected Cluster 1.0" je v súlade s direktívou 2014/53/EU.
Int Hungarian	Continental Automotive Components Magyarország nyilatkozik, hogy "Continental Connected Cluster 1.0" típusú rádióeszköz megfelel a 2014/53/EU irányelvnek.
Int Romanian	Eu, producătorul, Continental Automotive Components Malaysia, achem să declar în conformitate cu Directiva 2014/53/UE.

1930-0019 1.0

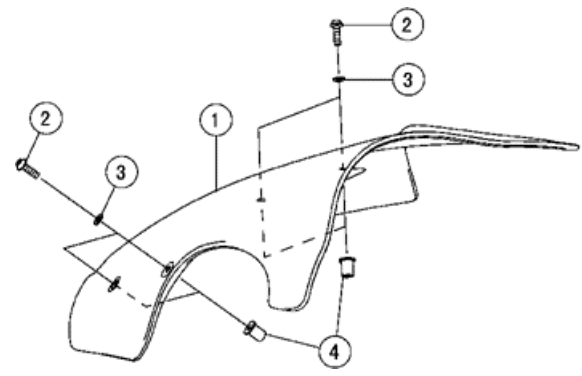

Pre-assembly exploded windshield

Dichiarazione CE strumentazione radio
(da stampare, piegare ed inserire nella busta)

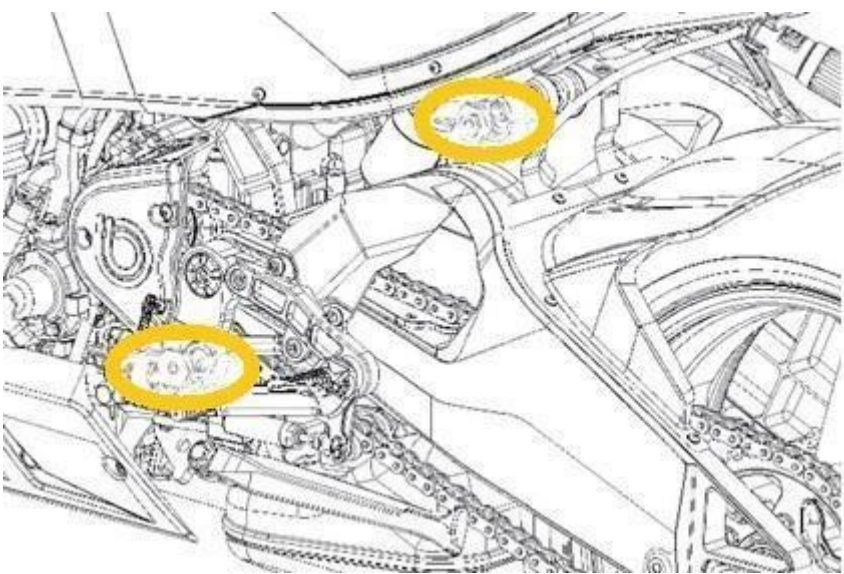

Adjuster point

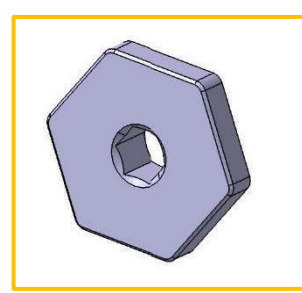

Eccentric adjuster

Parts Check

- Open the parts box, and check the parts against the illustrations. There may be minor differences between the illustrations and the actual vehicle parts. In the following chart remarks, D =diameter in millimeters, and L=length in millimeters.

No.	Part Name	Qty	Remarks
1	windshield	1	
2	socket Bolt, Windshield	6	D=4,L=12
3	nylon Washer, Windshield	6	D = 4 × 9
4	wellnut, Windshield	6	D=4
5	mirror assy	2	
6	motorcycle cover	1	
7	warranty book	1	
8	joint mirror assy (n.2 M6x16,n.washer D6, n.2 joint mirror)	2	
9	eccentric adjuster	1	
10	tool kit	1	

Assembly

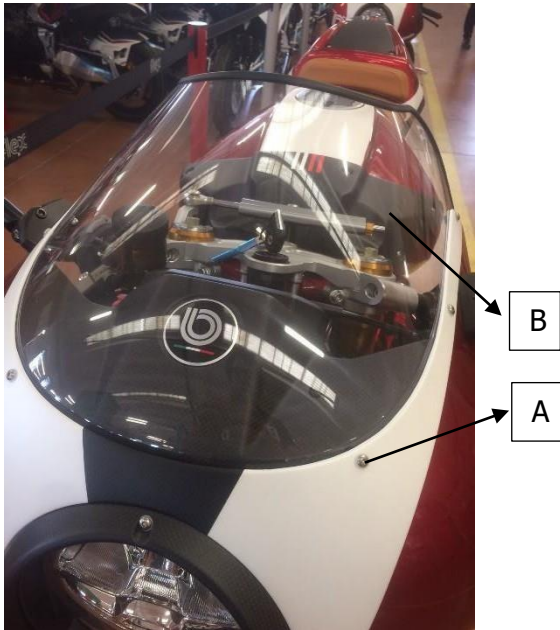

- A. Plastic washers (D=4×9) and screw (D=4,L=12) and wellnut D4
- B. Windshield

Windshield

Fit the six wellnuts (D=4) in to the wind-shield bracket holes from the outside with their flanges out.

Mirror assy

Take an allen key 5, an M6x16 screw and a washer D6 and a drop of loctite.
Adjust the mirrors in the 2 joints as shown in the pictures below.



Preparation

Battery Service

The battery used in this motorcycle is a sealed type and never needs to be refilled. Follow the procedure for activating a new battery to ensure the best possible battery performance.

Battery Removal

- Take an allen key 3 to remove the screws. [A]
- Lift seat closure [B]



A. Screws

B. Seat closure

- Remove the rider's seat and the battery.
- Disconnect the negative cable (-) from the negative terminal
- Slide the red cap from the positive terminal
- Take the battery out from the battery case



Make	GSYUASA
Type	YTZ10S
Features	9.1Ah 190CCA

The battery installed in this motorcycle is sealed type, so it is not necessary to check the battery electrolyte level or add distilled water.

Battery Installed

Place the battery on the battery case. Connect the positive (+) cable to the Positive (+) terminal, and black cable to the negative (-) terminal.

Battery Maintenance

It is the owner's responsibility to keep the battery fully charged. Failure to do so can lead to battery failure and leave you stranded.

If you are riding your vehicle infrequently, inspect the battery voltage weekly using a voltmeter. If it drops below 12.8 volts, the battery should be charged using an appropriate charger (check with your Bimota dealer). If you will not be using the motorcycle for longer than two weeks, the battery should be charged using an appropriate recharger. Do not use an automotive type quick charger that may over-charge the battery and damage it.

NOTE

○ Leaving the battery connected causes the electrical components (clocketc.) to make the battery discharged, resulting the overdischarge of the battery. In this case, the repair or replacement of the battery is not included in the warranty. If you do not drive for four weeks or more, disconnect the battery from the vehicle.

<i>NOTICE</i>
Installing the negative (-) cable to the positive (+) terminal of the battery or the positive (+) cable to the negative (-) terminal of the battery can seriously damage the electrical system.

Battery Charging

Charge the battery following the instructions of your battery charger. The charger will keep the battery fully charged until you are ready to reinstall the battery in the motorcycle (see Battery Installation).

Clean the battery using a solution of baking soda and water. Be sure that the cable connections are clean. Put a light coat of grease on the terminals to prevent corrosion.

Cover the positive (+) terminal with the red cap ed install seat.

Engine Oil

Oil Level check

- If the engine is cold, start the engine and run it for several minutes at idle speed.
- Stop the engine, then wait several minutes until the oil settles.

NOTICE

Racing the engine before the oil reaches every part can cause engine seizure.

- Check the engine oil level through the oil level inspection window. With the motorcycle held level, the oil level should come up between the upper and lower level lines next to the oil level inspection window.

Tightening Torque

Oil Filter:
17N·m(1.7kgf·m,13ft·lb)
Engine Oil Drain Bolt:
29N·m(3.0kgf·m,21ft·lb)

- Fill the engine up to the upper level Line with a good quality engine oil Specified in the table.

Recommended Engine Oil

Type:
APISG, SH, SJ, SL or SM with JASO MA, MA1 or MA2
rating Viscosity:
SAE10W-40

NOTE

- Do not add any chemical additive to the oil. Oils fulfilling the above requirements are fully formulated and provide adequate lubrication for both the engine and the clutch.

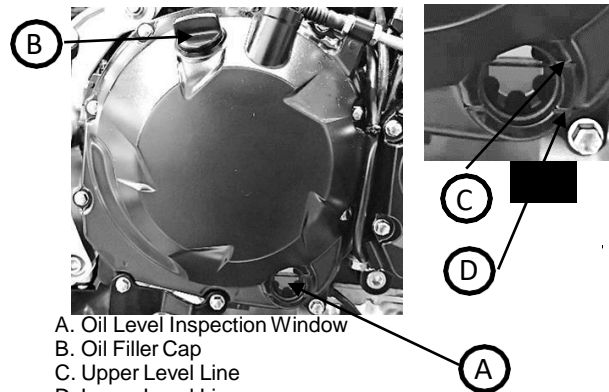

- A. Oil Level Inspection Window
- B. Oil Filler Cap
- C. Upper Level Line
- D. Lower Level Line

- If the oil level is too high, remove the excess oil through the oil filler opening using a syringe.

If the oil level is too low, add oil to reach the correct level. Use the same type and brand of oil that is already in the engine.

Engine Oil Capacity

3.2L(3.4USqt)
[when filter is not removed]
3.8L(4.0USqt)[when filter is removed]

Although 10W-40 engine oil is recommended for most conditions, the oil viscosity may need to be changed to accommodate atmospheric conditions in your riding area.

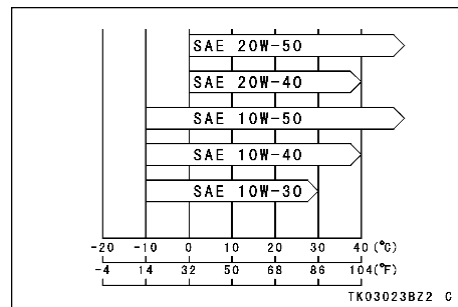

Coolant

Coolant Level Inspection

- Position the motorcycle so that it is perpendicular to the ground.
- Check the coolant level through the Coolant level gauge on the reserve tank located to the behind of the front fork. The coolant level should be between the F (Full) and L (Low) level lines.

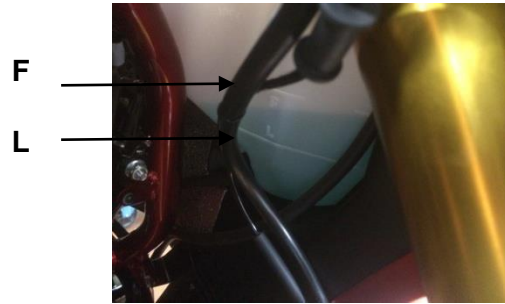

NOTE

○ Check the level when the

engine

is cold (room or atmospheric temperature).

- If the amount of coolant is insufficient, add coolant into the reserve tank.

NOTE

○ In an emergency you can add water

alone to the coolant reserve tank, however it must be returned to the correct mixture ratio by the addition of antifreeze concentrate as soon as possible.

Coolant Filling

Remove the cap from the reserve tank and add coolant through the filler opening to the F(Full) level line.



A. Reserve Tank Cap

NOTICE

If coolant must be added often, or the reserve tank completely runs dry, there is probably leakage in the system. Have the cooling system inspected by your authorized Bimota dealer.

Coolant Requirement

 **WARNING**

Coolant containing corrosion inhibitors for aluminum engines and radiators include harmful chemicals for human body. Drinking coolant can result in serious injury or death. Use coolant in accordance with the instructions of the manufacturer.

Use a permanent type of antifreeze (soft water and ethylene glycol plus corrosion and rust inhibitor chemicals for aluminum engines and radiators) in the cooling system. On the mixture ratio of coolant, choose the suitable one referring to the relation between freezing point and strength directed on the container.

NOTICE

If hard water is used in the system, it causes scale accumulation in the water passages, and considerably reduces the efficiency of the cooling system.

NOTE

- *A permanent type of antifreeze is installed in the cooling system when shipped. It is mixed at 50% and has the freezing point of -35°C (-31°F).*

Clutch

Clutch Operation Inspection

Check that the clutch lever operates properly and that the inner cable slides smoothly. If there is any irregularity, have the clutch cable checked by an authorized Bimota dealer.

- Check the clutch lever free play.

Clutch Lever Free Play

2~3mm(0.08~0.12in.)

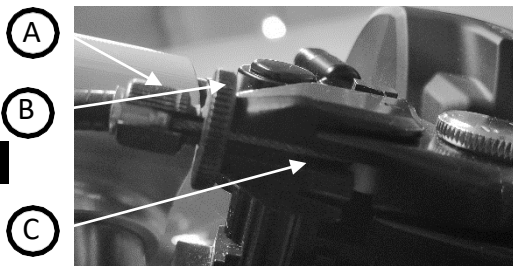

- A. Adjuster
- B. Locknut
- C. Clutch Lever Free Play

⚠ WARNING

Excess clutch lever free play could prevent clutch disengagement and cause a crash resulting in serious injury or death. When adjusting the clutch lever free play, be sure the upper end of the clutch outer cable is fully seated in its fitting so that it doesn't slip into place later and create excessive free play.

- If the free play is incorrect, adjust the clutch lever free play as follows.

Clutch Lever Free Play Adjustment

- Loosen the locknut, and turn the adjuster so that the clutch lever will have the specified free play.

Tighten the locknut.

- If it cannot be done, have the clutch cable adjusted by an authorized Bimota dealer.

NOTE

- After the adjustment is made, start the engine and check that the clutch does not slip and that it releases properly

Drive Chain

Drive Chain Lubrication

Lubrication is necessary after riding through rain or on wet roads, or any time that the chain appears dry.

Use a lubricant for sealed chains to

Prevent deterioration of chain seals. If the chain is especially dirty, clean it using a cleaner for sealed chains following the instructions supplied by the chain cleaner manufacturer.

- Apply lubricant to the sides of the Rollers so that it will penetrate to the rollers and bushings.

Apply lubricant to the seals so that the seals will be coated with lubricant. Wipe off any excess lubricant.

Wipe off any lubricant that gets on the tire surface.

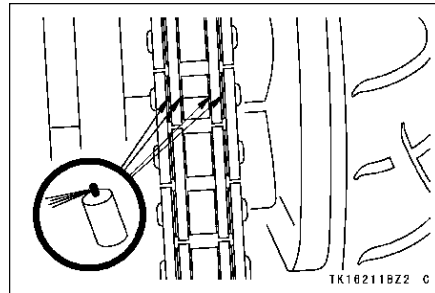

Drive Chain Slack Inspection

Set the motorcycle up on its side stand.

- Clean the chain if it is dirty, and lubricate.
- Rotate the rear wheel to find the position where the chain is tightest, and Measure the maximum chain slack by pulling up and pushing down the chain midway between the engine sprocket and rear wheel sprocket

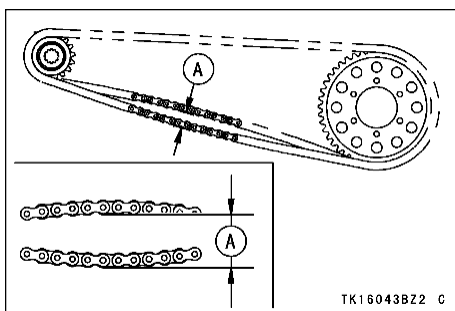

A. Chain Slack

- If the drive chain is too tight or too loose, adjust it so that the chain slack is within the standard value.

Drive Chain Slack

Standard: 25~35mm (1~1.35in.)

Drive Chain Slack Adjustment

Loosen the rear wheel axle

- Adjust left and right chain bolt to Realize the right tigh of chain
- Check that the mark on the chain adjuster are at the same position on the left and right sides.
- Rotate the wheel, measure the chain slack again at the tightest position, and readjust if necessary.
- Rotate both chain adjuster bolts to get right alignment of wheel.

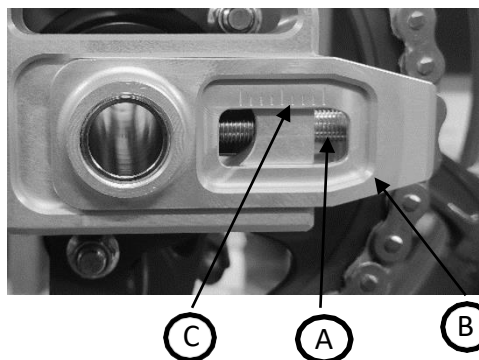

A. Chain Adjuster Bolt
B. Chain Adjuster
C. Marks



WARNING

A loose clamp bolt can lead to an accident resulting in serious injury or death. Tighten the clamp bolts to the proper torque.

- Check the rear brake (see Brakes section in this chapter).

Brakes

If you feel there is something wrong when applying the brakes, have the brake system checked by an authorized Bimota dealer immediately.

Brake Fluid Level Inspection

With the brake fluid reservoirs held horizontal, the brake fluid level must be kept between the upper and lower level lines.



WARNING

Misalignment of the wheel will result in abnormal wear, and may result in an unsafe riding condition. Align the rear wheel using the marks on the swingarm or measuring the distance between the center of the axle and swingarm pivot.



WARNING

Air in the brake lines diminish braking performance and can cause an accident resulting in injury or death. If the brake lever or pedal feels mushy when it is applied, there might be air in the brake lines or the brake may be defective. Have the brake checked immediately by an authorized Bimota dealer.

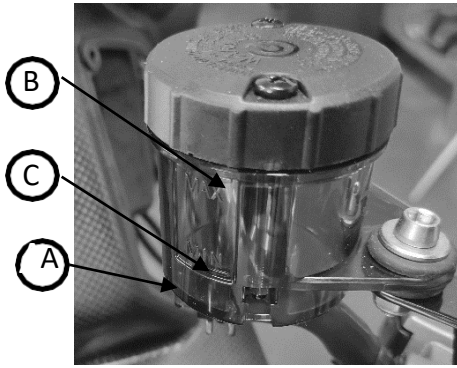

A. Front Brake Fluid Reservoir
 B. Upper level Line
 C. Lower level Line

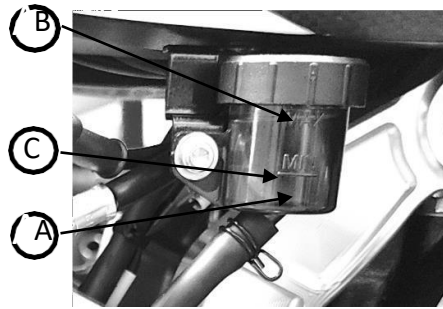

A. Rear Brake Fluid Reservoir
 B. Upper level Line
 C. Lower level Line

- If the fluid level is lower than the lower level line it may indicate that the fluid is leaking.

In this case, have the brake system inspected by an authorized Bimota dealer.

Brake Pad Wear Inspection

Inspect the brakes for wear. For each front and rear disc brake caliper, if the thickness of either pad lining is less

than below table, replace both pads in the caliper as a set. Pad replacement should be done by an authorized Bimota dealer.

Lining Thickness Service Limit

Front	1.0mm(0.04in.)
Rear	1.0mm(0.04in.)

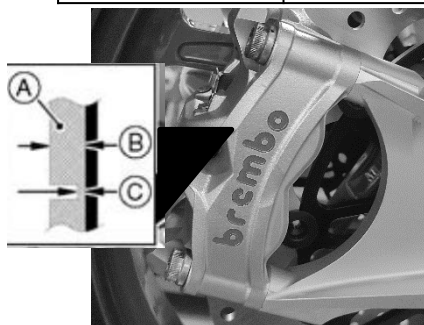

A. Front Brake Pads
 B. Lining Thickness
 C. Service Limit

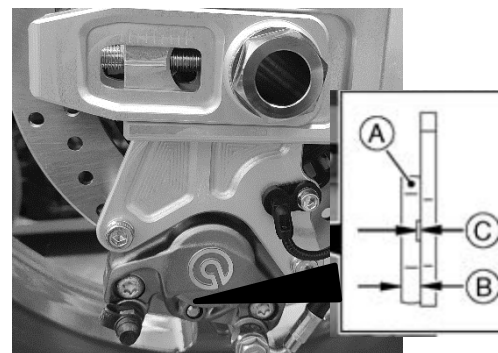

A. Rear Brake Pads
 B. Lining Thickness
 C. Service Limit

Brake Light Switches

Brake Light Switch Inspection

Turn the ignitions witch on.

- The brake light should go on when the front brake is applied and or the rear brake is applied.
- If it does not, ask your authorized Bimota dealer to inspect the front Brake lights witch and or the rear brake light switch.

Suspension System

Front Fork

WARNING

Improper fork leg adjustment can cause poor handling and loss of stability, which could lead to an accident. Always adjust the fork legs on the left and right side to the same setting.

NOTICE

After riding on the normal road, the unpaved road and in the rainy weather, clean off any dirt (grit, mud or insect etc.) that stuck to inner tube before it hardens. If the motorcycle keeps running with the dirt stuck to the inner tube, the oil seal will be damaged and it causes the oil leak.



Spring Preload Adjustment

The adjuster is located at the top of each front fork leg.

Standard

8 turns in

In from the fully seated position
(turned fully counterclockwise).

Turn the adjuster clockwise with a wrench (14mm) to increase spring preload and stiffen the suspension.

- Turn the adjuster counterclockwise
To decrease spring preload and soften the suspension.

NOTICE

Do not turn the adjuster beyond the fully seated position or the adjusting mechanism may be damaged.

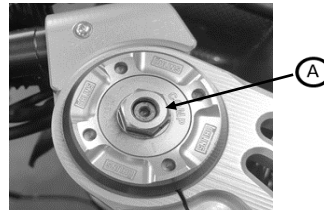

A. Spring Preload Adjuster

Rebound Damping Force Adjustment

The adjuster is located at the top of the right front fork leg.

NOTICE
Do not turn the adjuster beyond the fully seated position or the adjusting mechanism may be damaged.

Standard

20 click closed
Out from the fully closed position (turned fully clockwise).

- Turn the adjuster clockwise with 3 mm allen key to increase damping force

Turn the adjuster counter clockwise to decrease damping force.



NOTICE
Do not turn the adjuster beyond the fully seated position or the adjusting mechanism may be damaged.

Compression Damping Force Adjustment

The adjuster is located at the top of the left front fork leg

Standard

20 click closed
Out from the fully closed position (turned fully clockwise).

Turn the adjuster clockwise with a 3 mm allen key to increase damping force.

Turn the adjuster counter clockwise to decrease damping force.



Rear Shock Absorber

NOTICE

Do not turn the adjuster beyond the fully seated position or the adjusting mechanism may be damaged.

Spring Preload Adjustment

The adjuster is located on the right side on the muffler bracket.

Standard

12 clicks

In from the fully seated position (turned fully counter clockwise).

- Turn the adjuster clockwise to increase spring preload.
- Turn the adjuster counter clockwise To decrease spring preload.

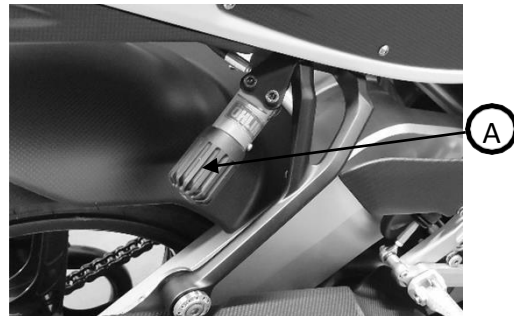

Rebound and Compression Damping Force Adjustment

The adjusters are located at the upper end of the rear shock absorber.

Standard

22 clicks turns out

Out from the fully seated position (turned fully clockwise).

- Turn the adjuster clockwise with an Allen key 3 mm to increase damping force.
- Turn the adjuster counter clockwise to decrease damping force.

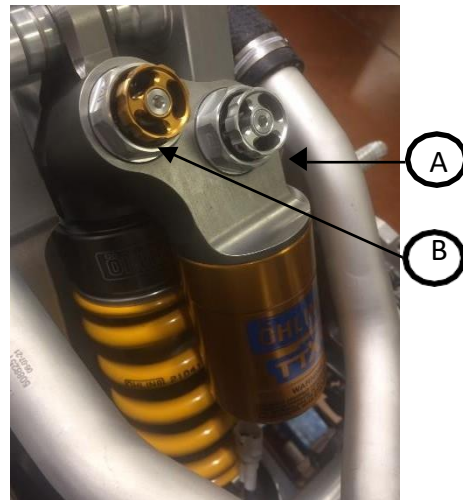

A. Rebound Damping Force Adjuster
B. Compression Damping force Adjuster

NOTICE

Do not turn the adjuster beyond the fully seated position or the adjusting mechanism may be damaged.

Setting tables

Front Fork Spring Preload Setting

	Softest setting limit	Standard	Hardest setting limit
Adjuster Position	18	8 turns in**	18 turns in**
Spring Action	Weak	↔	Strong
Setting	Soft	↔	Hard
Load	Light	↔	Heavy
Road	Good	↔	Bad
Speed	Low	↔	High

*:This position is the fully seated position(turned fully counterclockwise).

**:.In from the fully position (turned fully counterclockwise).This adjustment range may not exactly match the number shown in the table due to small tolerance of production.

Front Fork Damping Force Settings

		Softest setting limit	Standard	Hardest setting limit
Adjuster Position	Rebound	23 turns out**	20 click out**	0*
	Compression	23 turns out**	20 click out**	0*
Pre-load spring		0*	8	
Damping Force		Weak	↔	Strong
Setting		Soft	↔	Hard
Load		Light	↔	Heavy
Road		Good	↔	Bad
Speed		Low	↔	High

*: This position is the fully seated position(turned fully clockwise).

**:. Out from the fully seated position (turned fully clockwise).This adjustment range may not exactly match the number shown in the table due to small tolerance of production.

Rear Shock Absorber Spring Preload Setting

	Softest setting limit	Standard	Hardest setting limit
Compression Position	44	22 clicks**	0
Rebound position	54	22 click**	0
Spring pre-load	0*	8 turns	18 turns
Spring Action	Weak	←→	Strong
Setting	Soft	←→	Hard
Load	Light	←→	Heavy
Road	Good	←→	Bad
Speed	Low	←→	High

*: This position is the fully seated position(turned fully counterclockwise).

** : In from the fully seated position(turned fully counterclockwise).This adjustment range may not exactly match the number shown in the table due to small tolerance of production.

Rear Shock Absorber Rebound Force Setting

		Softest setting limit	Standard	Hardest setting limit
Adjuster Position	Rebound	54	22	0*
Damping Force		Weak	←→	Strong
Setting		Soft	←→	Hard
Load		Light	←→	Heavy
Road		Good	←→	Bad
Speed		Low	←→	High

*: This position is the fully seated position (turned fully clockwise).

** : Out from the fully seated position (turned fully clockwise). This adjustment range may not exactly match the number shown in the table due to small tolerance of production.

Rear Shock compression Force Setting

		Softest setting limit	Standard	Hardest setting limit
Adjuster Position	Rebound	44	22	0*
Damping Force		Weak	←→	Strong
Setting		Soft	←→	Hard
Load		Light	←→	Heavy
Road		Good	←→	Bad
Speed		Low	←→	High

Wheels

Tire Pressure Inspection

Remove the air valve cap.

- Check the tire pressure often, using an accurate gauge.
- Make sure to install the air valve cap securely.

NOTE

○ *Measure the tire pressure when the tires are cold (that is, when the motorcycle has not been ridden more than 1.6 km (1 mile) during the past 3 hours).*

○ *Tire pressure is affected by changes in ambient temperature and altitude, and so the tire pressure should be checked and adjusted when your riding involves wide variations in temperature or altitude.*

Headlight

Headlight aiming should be done by an authorized Bimota dealer.

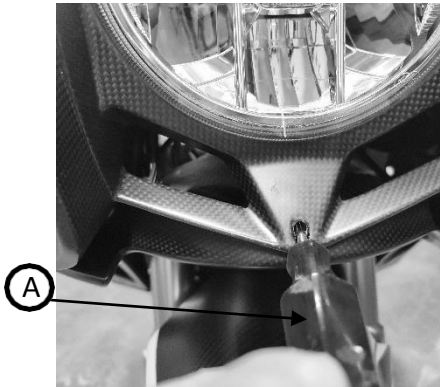

A. Vertical Adjusters

Vertical Adjustment

The headlight beam is adjustable vertically with a screwdriver. If adjusted too low, neither low nor high beam will illuminate the road far enough ahead. If adjusted too high, the high beam will fail to illuminate the road close ahead, and the low beam will blind oncoming drivers

- Turn the vertical adjuster in or out to Adjust the headlight vertically.

NOTE

- On high beam, the brightest point should be slightly below horizontal with the motorcycle on its wheels and the rider seated. Adjust the headlight to the proper angle according to local regulations.

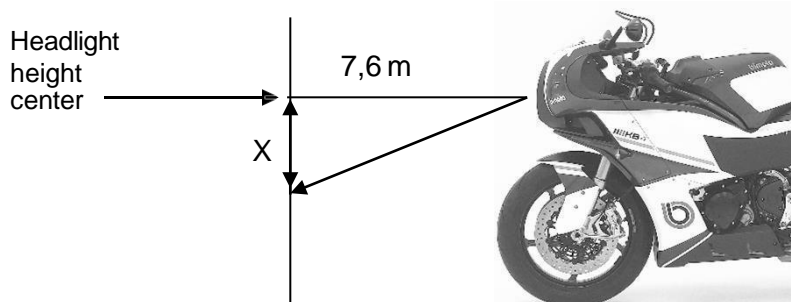

X=max 5 centimeters measured from the center of headlight with the motorcycle on the wheel and the driver seated

Cleaning from anticorrosive treatments

Clean the front and rear brake discs, swingarm, plate, right footrest support and left footrest support using alkaline solvent.



WARNING

An anticorrosive treatment applied to the brake discs will increase braking distance and can cause an accident resulting in serious injury or death. Remove the anticorrosive treatment using an oilless solvent.

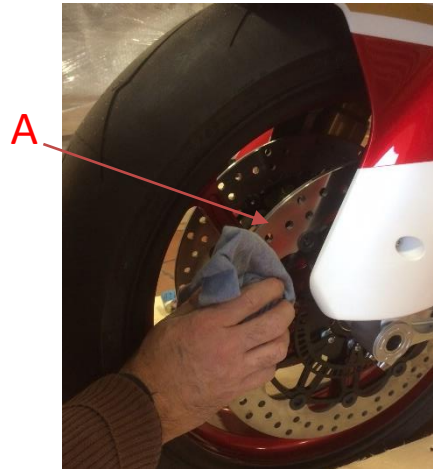

A.Brake disc